

Solex Egypt

Tel. : (+2) 0554334666

Mobile : (+2) 01208991111

E-mail : Info@solexegypt.com

Address : Plot No. 2 Zezenya Industrial Park, Ismailia Desert Road

www.solexegypt.com



ابتكر حياتك innovate life

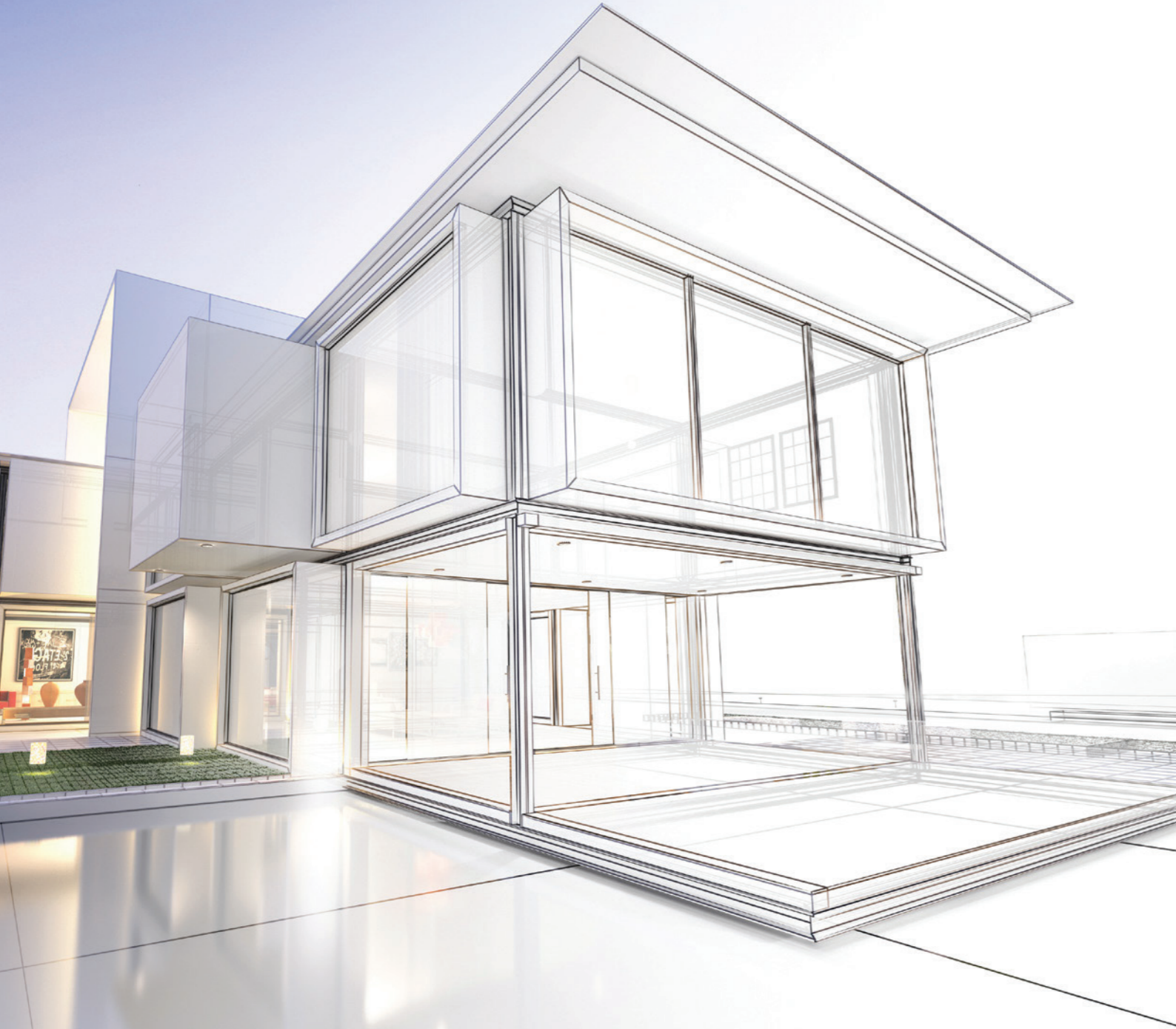

Introduction

مقدمة

SOLEX has been the market leader in the rolling shutter industry within Saudi Arabia for the past 35 years. SOLEX operates all over Egypt through it's new branch which is equipped with all necessary resources in Design, Manufacturing, installation and After-sales services to fulfill the market needs It also operates all over the Saudi Arabian market through its 3 plants, showrooms & offices spanning the Western, Central & Eastern regions. SOLEX fulfills customers' needs by offering the widest range of solutions for the fabrication of window shutters.

سوليكس هي الشركة الرائدة في صناعة الشتر في المملكة العربية السعودية على مدى السنوات ال 35 الماضية تنتشر الشركة حالياً على مستوى السوق المصري من خلال فرعها الجديد والذي يتمتع بالموارد المتخصصة المطلوبة لتلبية متطلبات السوق من تصميم وتصنيع وتركيب وخدمات ما بعد البيع، كما تنتشر شركة سوليكس على مستوى السوق السعودي من خلال 3 مصانع و معارض و مكاتب في المنطقة الغربية والوسطى و الشرقية. تلبى الشركة احتياجات العملاء من خلال تقديمها مجموعة واسعة من أنظمة الشتر والألمنيوم الملائمة لقطاع البناء.

Shutter Systems أنظمة الشتر

Shutter Systems offer many benefits over traditional closure options. Shutters can be made to fit almost any opening. Our strategic partnerships have many years of experience, specializing in the design and development of rolling shutter components. We continually strive to offer professional service and as superior product.

تقدم أنظمة الشتر فوائد عديدة تتخطى الستائر التقليدية وتتناسب مع كل أنواع الفتحات. يتمتع شركاؤنا الإستراتيجيون بسنوات من الخبرة المتخصصة في تصميم وتطوير مكونات الشتر. كما نسعى جاهدين لتقديم الخدمات المهنية والمنتجات المميزة.



Components of an Aluminium Rolling Shutter

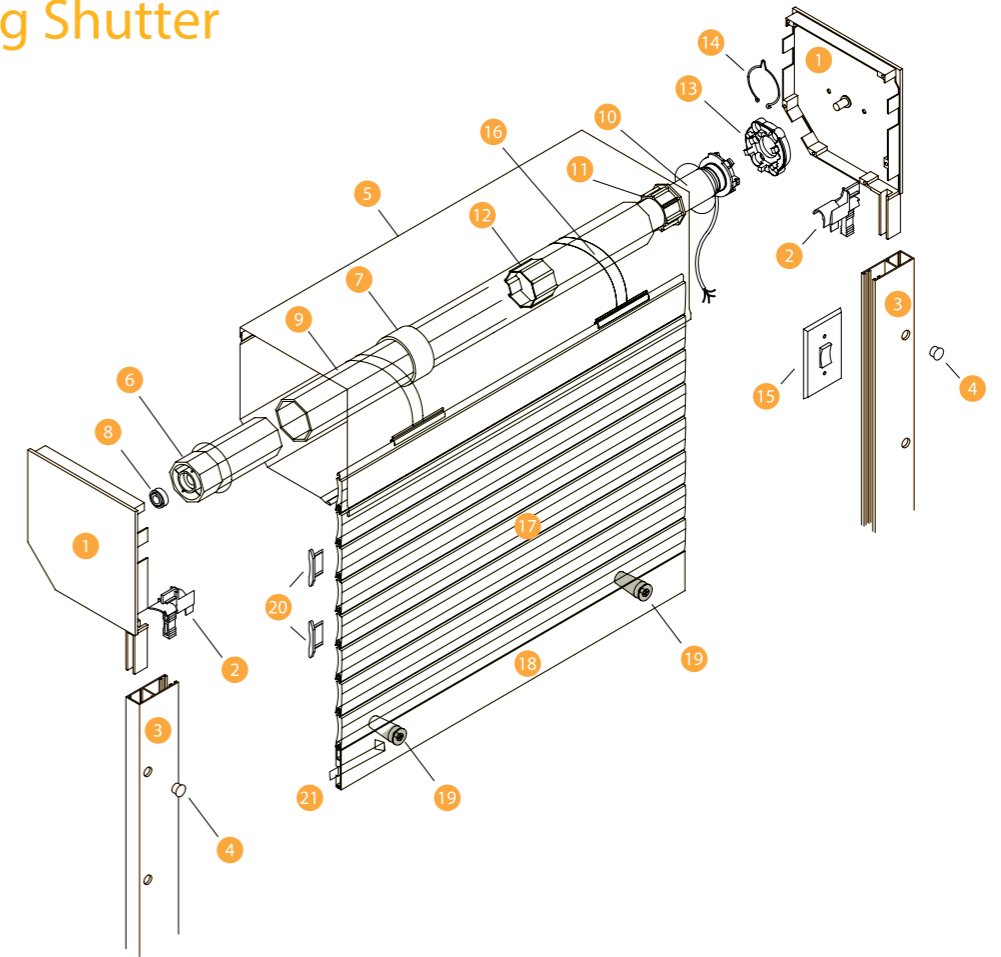

- 1 Side/End Cap
- 2 Entry Guide
- 3 Guide Channel
- 4 Plug Button
- 5 Box
- 6 Plastic Cap
- 7 Crown Adapter

- 8 Ball Bearing
- 9 Tube - Octagonal
- 10 Tubular Motor
- 11 Crown
- 12 Wheel
- 13 Motor Bracket
- 14 Spring Ring

- 15 Switch
- 16 Security Spring
- 17 Shutter Curtain
- 18 Terminal Profile
- 19 Plastic Stopper
- 20 Side Lock
- 21 Security Lock

Shutter Benefits

-  Security
الأمان
-  Protection from Sun
الحماية من الشمس
-  Energy Saving
حفظ الطاقة
-  Protection from Insects
الحماية من الحشرات

Slat Types

Extruded Aluminium Slats

شرائح الألمنيوم المسحوبة

Provide high security solutions for residential homes. Available in large sizes and many colours

تؤمن حلول حماية قصوى للمنازل. متوفرة بمقاسات كبيرة و ألوان متعددة

فوائد الشتر

-  Protection from Dust
الحماية من الغبار
-  Privacy
الخصوصية
-  Light Control
التحكم بالإضاءة
-  Noise Reduction
تخفيف الضوضاء

أنواع الشرائح

Insulated Aluminium Slats

شرائح الألمنيوم المعزولة

Made of lightweight materials, these slats provide insulation benefit against noise and heat.

مصنوعة من مواد خفيفة الوزن، تتميز هذه الشرائح بقدرة عزل الضوضاء و الحرارة.



7 Simple Steps When Choosing an Aluminium Rolling Shutter

1

Select Slat Type and Size

Based on dimensions of the opening and purpose of use

إختيار نوع وحجم الشريحة

بناء على مقاسات الفتحة والغاية من الاستخدام

2

Select Operating System: Motorized or Manual

Based on dimensions as well as customer convenience

إختيار نظام التشغيل: أوتوماتيكياً أو يدوياً

بناء على مقاسات الفتحة ورغبة العميل

3

Select The Optimal Installation Method

Based on building, construction and design

إختيار نظام التركيب الأمثل

بناء على المخطط الإنشائي والتصميم

4

Select Types Of Boxes, Guide Channels & Terminal Slats

Based on slat type, size, and the opening dimensions

إختيار أنواع الصناديق و القنوات الجانبية والشفرة النهائية

بناء على نوع الشفرة وحجمها ومقاسات الفتحة

5

Select Tube Type And Size

Based on opening dimensions and shutter weight

إختيار نوع الماسورة وحجمها

بناء على مقاسات الفتحة و وزن الشتر

6

Select Locking System

Based on the security and protection requirements

إختيار نظام الأقفال

بناء على متطلبات الأمن والحماية

7

Select Colors

Based on the building external finishing and individual choice.

إختيار الألوان

بناء على التشطيب الخارجي للمبنى والإختيار الشخصي

Select Slat Type and Size

Based on Dimensions of The Opening and Purpose of Use

ALURAY
Premium Aluminium Slats

"ALURAY" series of insulated and extruded slats have been the product of choice for the Saudi and GCC market

شرائح "الوراي" المعزولة و المسحوبة هي الخيار الأول في الأسواق السعودية و الخليجية

Coating Characteristics:

- Abrasion and scratch resistant
- Stretch and crack resistant
- UV resistant
- Corrosion resistant

خصائص الطلاء:

- مقاوم للخدوش عند الإحتكاك
- مقاوم للتمدد والتشقق
- مقاوم للأشعة فوق البنفسجية
- مقاومة عالية للصدأ

Type Of Aluminium Slats:

Extruded Slat
الشفرة المسحوبة

- High Security
حماية عالية
- Suitable for Large Openings
مناسبة للمقاسات الكبيرة
- Available in Variety of Colors
متوفرة بألوان متعددة

أنواع شفرات الألمنيوم:

Insulated Slat
الشفرة المعزولة

- Improve thermal Insulation
تحسن العزل الحراري
- Light Weight
خفيفة الوزن
- Noise Reduction
تخفف الضوضاء

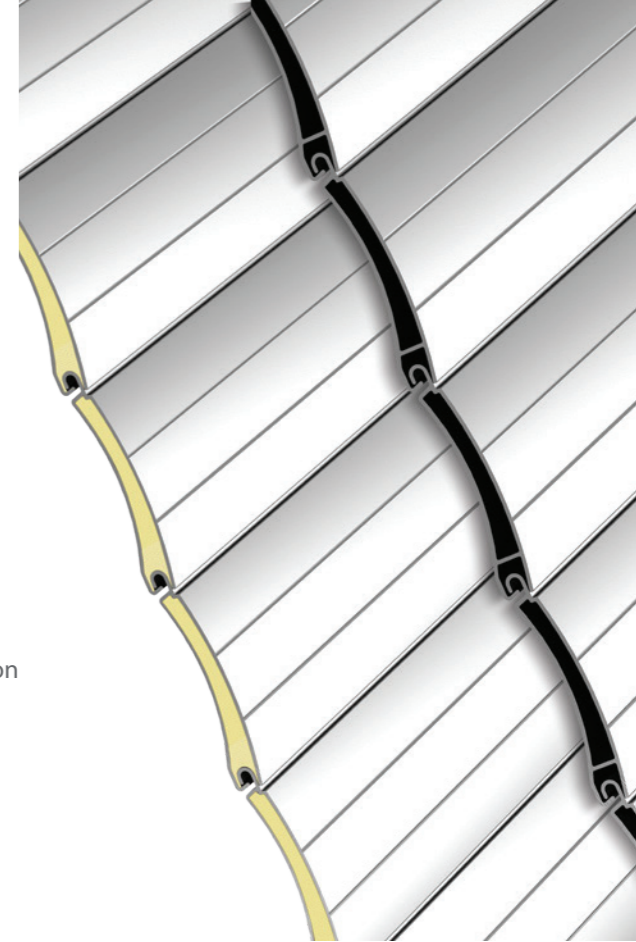

Types and Sizes of Slats

Insulated Aluminium Slats



SLI-41

Aluminium Thickness	0.29 mm
Width	9.0 mm
Weight per m ²	4.5 kg
Blind Surface	41.0 mm
Manufacturing Length	5.8 m
Maximum Usable Size	3.5 x 3.0 m

SLI-55

Aluminium Thickness	0.37 mm
Width	14.0 mm
Weight per m ²	5.5 kg
Blind Surface	55.0 mm
Manufacturing Length	5.8 m
Maximum Usable Size	4.0 x 4.0 m

SLI-77

Aluminium Thickness	0.39 mm
Width	18.2 mm
Weight per m ²	7.5 kg
Blind Surface	77.0 mm
Manufacturing Length	7.0 m
Maximum Usable Size	4.0 x 3.5 m

Insulation: Polyurethane foam to meet Gulf region Standards

Extruded Aluminium Slats

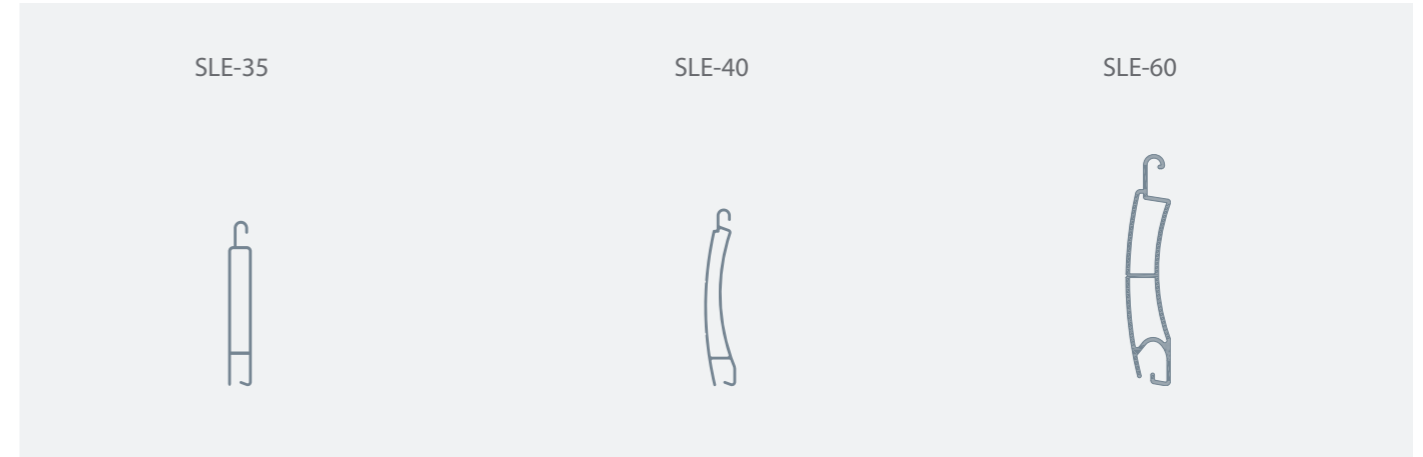

SLE-35

Aluminium Thickness	1.1 mm
Width	7.8 mm
Blind Surface	35.0 mm
Weight per m ²	9.5 kg
Manufacturing Length	5.8 m
Maximum Usable Size	4.8 x 4.0 m

SLE-40

Aluminium Thickness	1.0 mm
Width	9.3 mm
Blind Surface	40.0 mm
Weight per m ²	9.0 kg
Manufacturing Length	5.8 m
Maximum Usable Size	4.0 x 4.0 m

SLE-60

Aluminium Thickness	1.3 mm
Width	14.0 mm
Blind Surface	60.0 mm
Weight per m ²	11.0 kg
Manufacturing Length	6.0 m
Maximum Usable Size	5.8 x 4.5 m



SOLEX offers SOLA RAY systems to operate solar powered shutters produced by Somfy. SOLA RAY offers several benefits i.e. ease of installation without power supply or electric wiring.

توفر سوليكس نظام **سولاراي** لتشغيل الشتر الذي يعمل بالطاقة الشمسية من شركة سومفي، بحيث يتمتع بمزايا عديدة منها سهولة التركيب بدون تمديدات كهربائية.

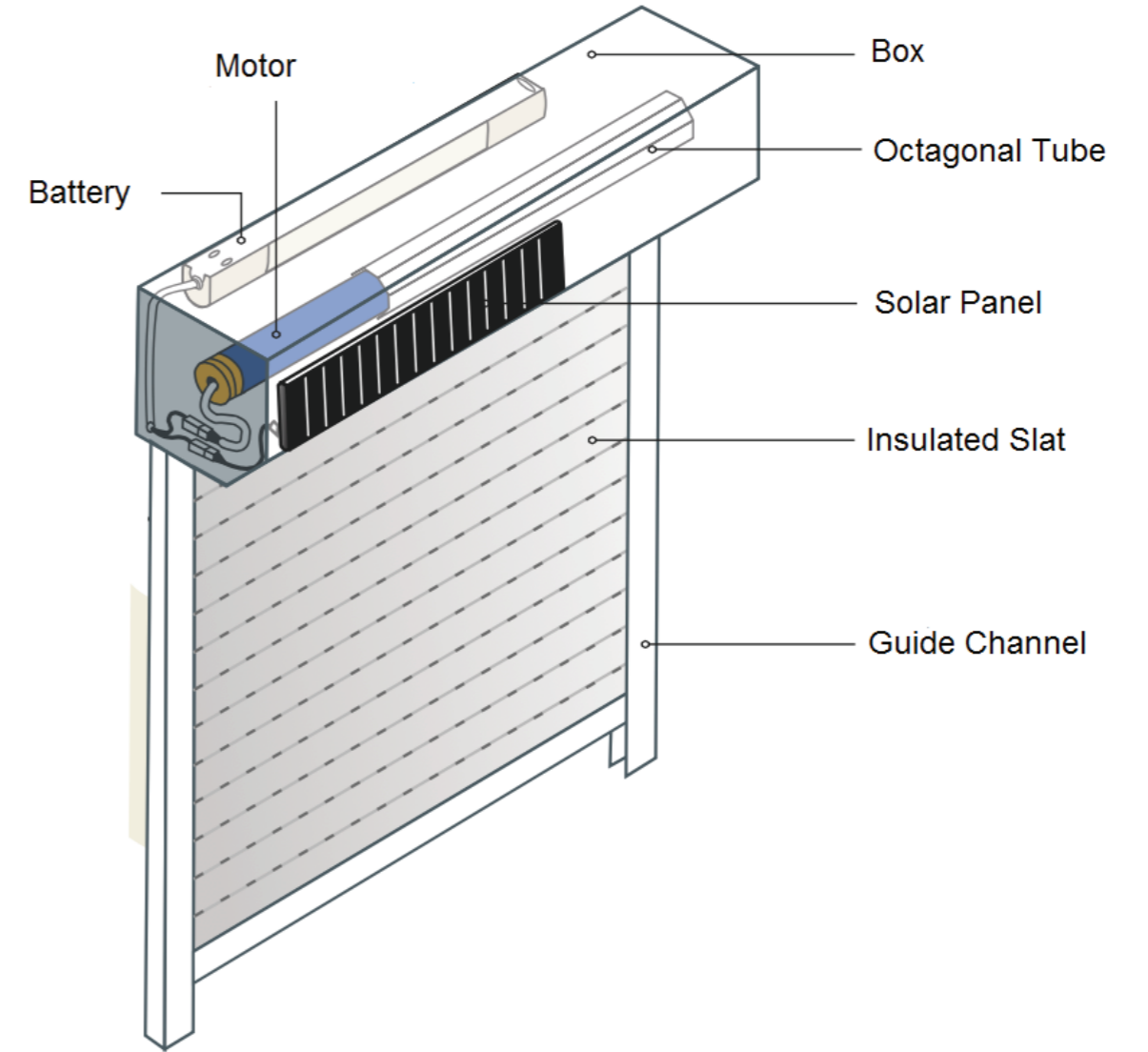

Installation Options

Built In Wall

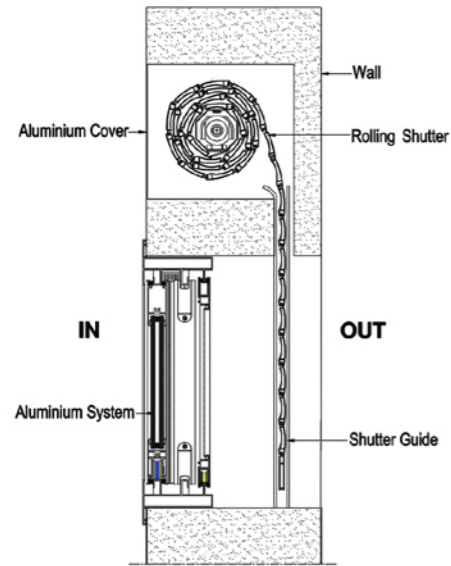

Monobloc

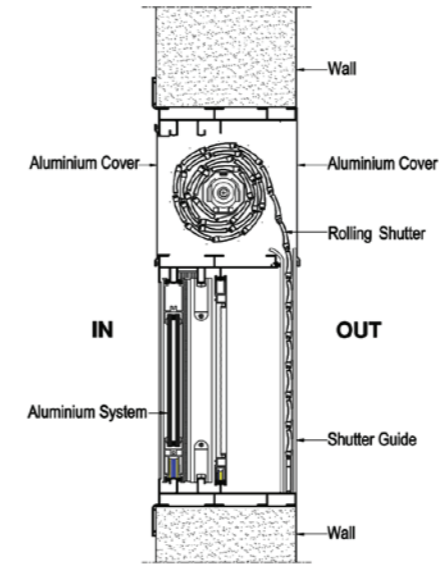

Flush To Wall

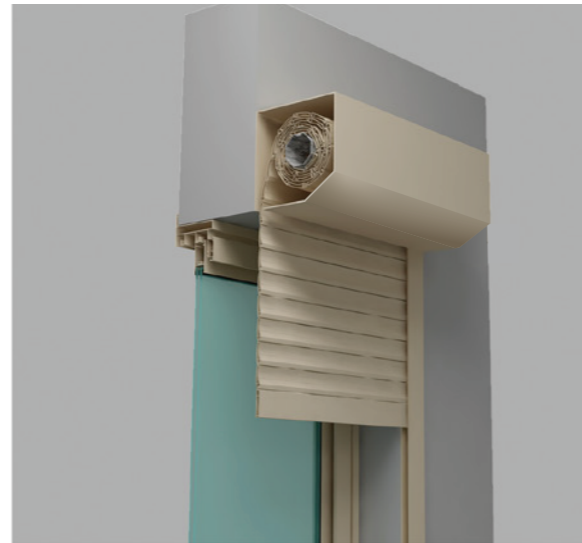
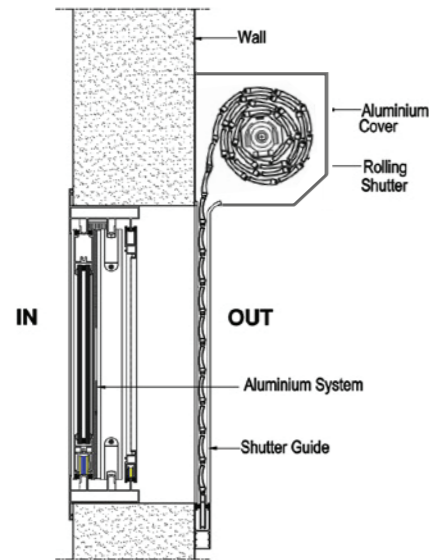

Flush To Aluminium

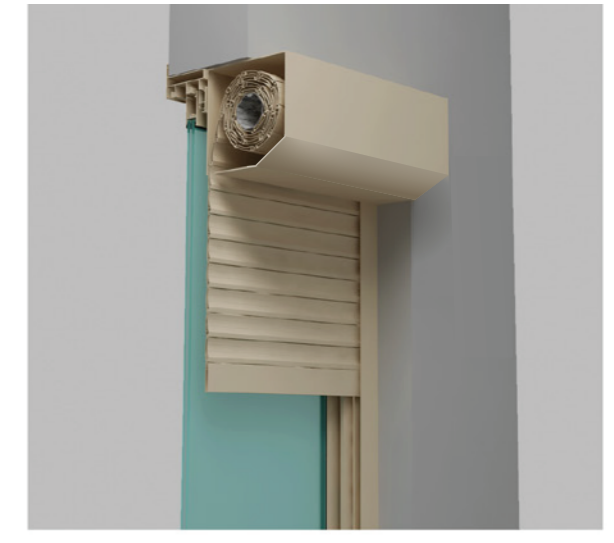
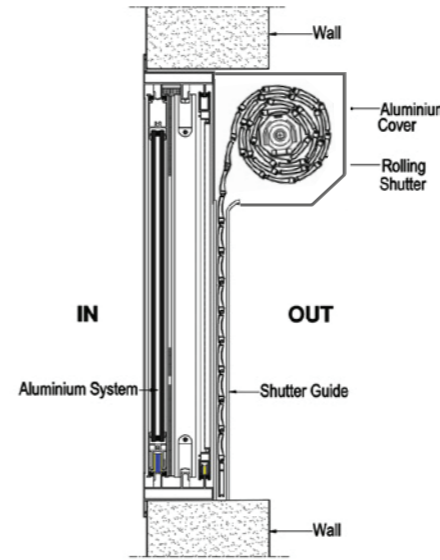

Boxes

Select Types Of Boxes, Guide Channels & Terminal Slats
Based on Slat Type, Size and the Opening Dimensions

Type Of Boxes and Side Frames

90 Degrees

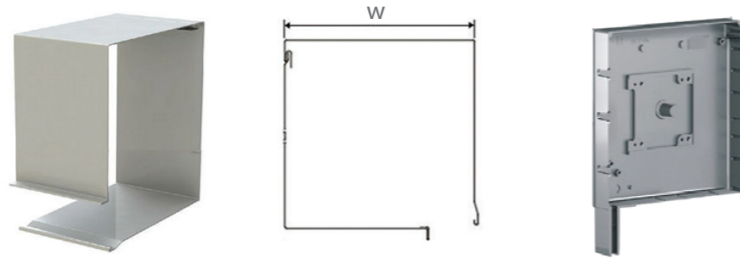

Width	
150 mm	205 mm
165 mm	250 mm
180 mm	

45 Degrees

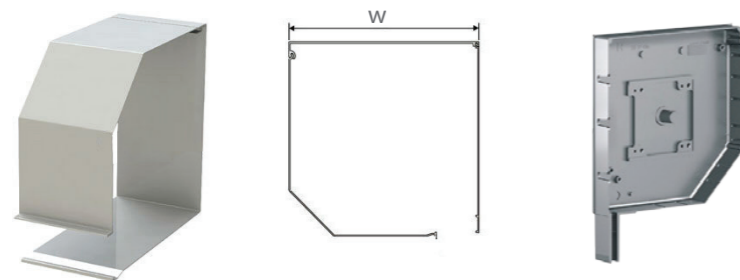

Width	
165 mm	250 mm
180 mm	300 mm
205 mm	

Guide Channels

GC-53

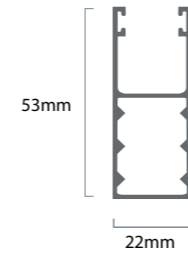

Compatible with Slats
(ES/IS 35,40,41 & 43 mm)

GC-66

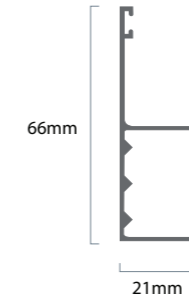

Compatible with Slats
(ES/IS 55 & 60 mm)

GC-95

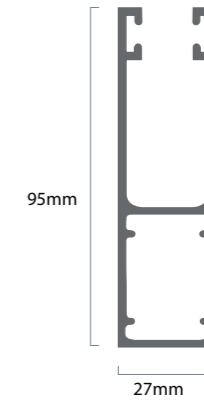

Compatible with Slats
(ES/IS 55 & 60 mm)

GC-950

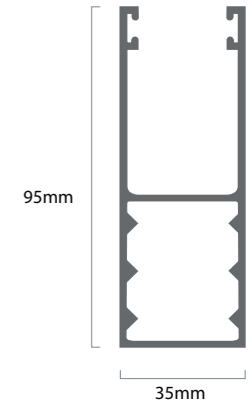

Compatible with Slats
(ES/IS 77 & 103 mm)

Terminal Slats

TS



TSL



Without Lock

Aluminium Thickness	1.0 mm
Height	50.0 mm
Compatible With	ES/IS 35 & 40

With Lock

Aluminium Thickness	1.0 mm
Height	53.0 mm
Compatible With	ES/IS 35 & 40

Tubes

Select Tube Type And Size

Based on Opening Dimensions and Shutter Weight

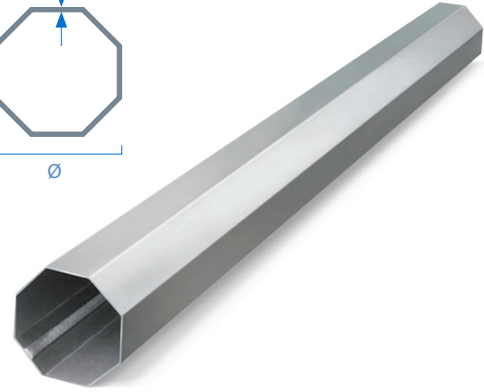
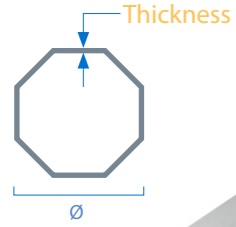

Tube Ø	40 mm	60 mm	70 mm
Available Thickness	0.40 mm	0.60 mm	1.2 mm
	0.60 mm	0.80 mm	1.5 mm

Octagonal Tubes

Tube Selection Chart

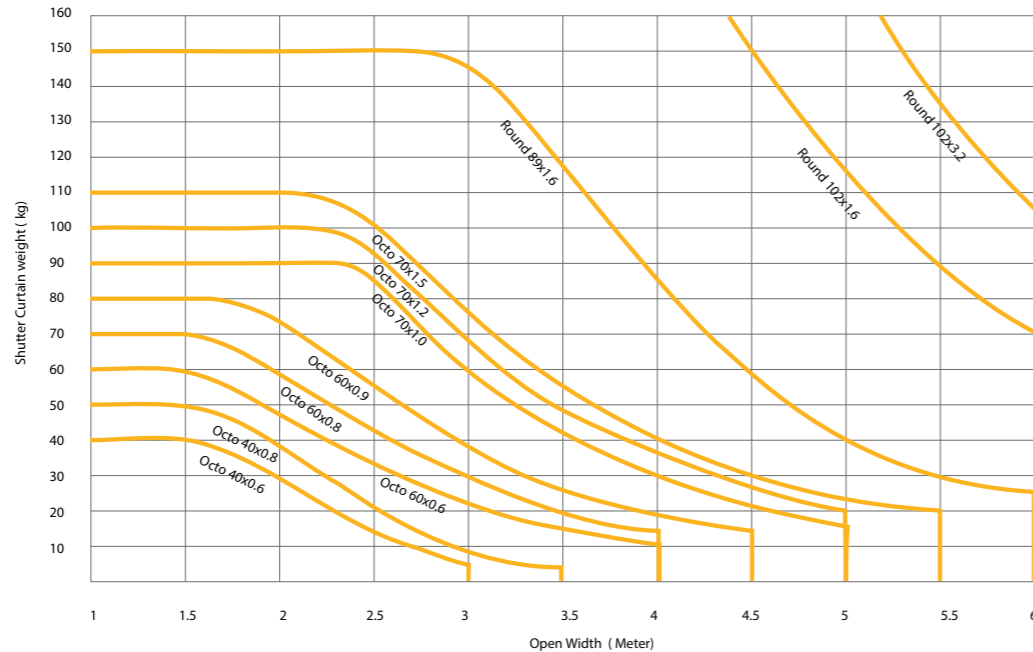

Locking

Select Locking System

Based on the Security and Protection Requirements

Taking into account requirements for security and functionality, we offer several options of locking systems.

أخذين بعين الاعتبار متطلبات الأمان، نقدم مجموعة من أنظمة الإقفال

Hand Lock

The roller shutters can be locked from the inside using the sliding lock.



الإقفال اليدوية

يمكن إقفال الشتر من الداخل بواسطة قفل منزلق.

Security Spring

The security spring system (Blocksur) forces down the shutter for increased safety and protection.



لاقط الأمان

نظام يعزز مستوى الأمان والسلامة عن طريق الضغط العكسي على الشتر

Key Switch

To operate the commercial gates using an automatic key switch.



مفتاح التحكم التلي

التحكم بالبوواب التجارية بواسطة مفتاح التحكم التلي.

Colors

Select Colors

Based on the Building External Finishing and Individual Choice.

Standard Colors

الألوان الأساسية

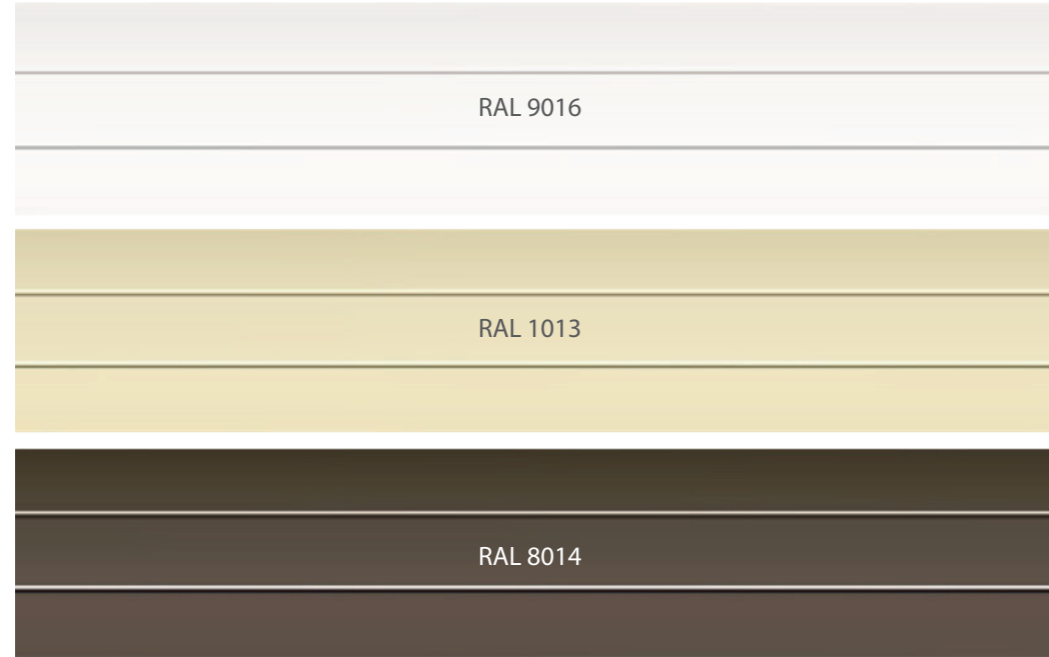

- Insulated slats are available in standard colours
- Extruded slats are available in a variety of colours (Over 100 different RAL Colours) in additional to standard colours

- الشريحة المعزولة متوفرة بالألوان الأساسية
- الشريحة المسحوبة متوفرة بألوان متعددة (أكثر من 100 لون رال) بالإضافة للألوان الأساسية

Manual Operators

Gear Records

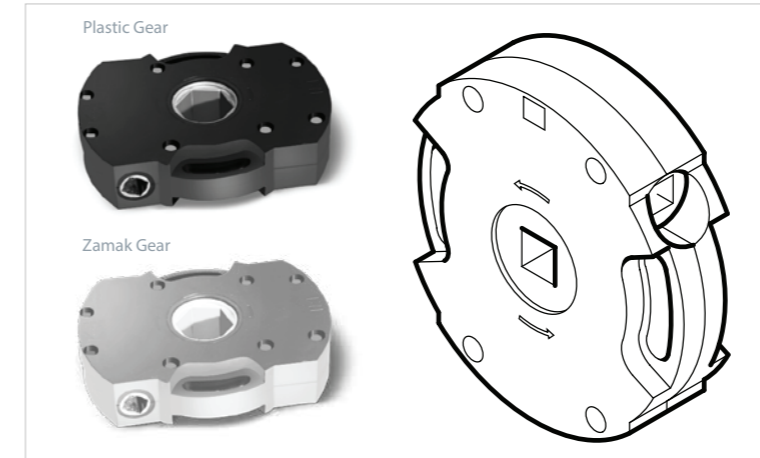

Handle Joint

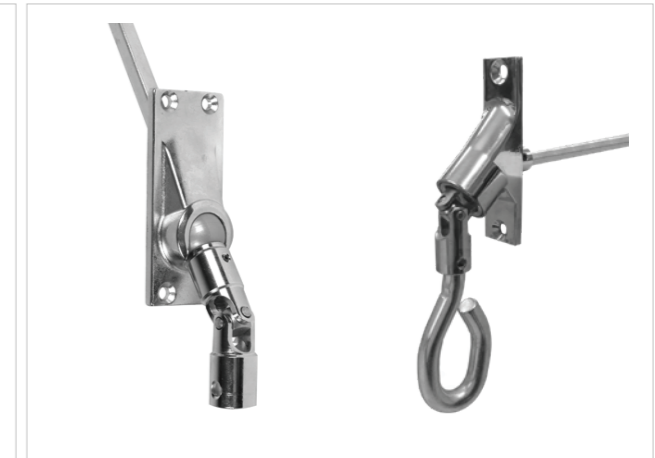

Stopper



Handle Lock



Cranks and Handles



Motorized

Select Operating System: Motorized or Manual
Based on dimensions as well as customer convenience

Motorized Operators

Tubular Motor Components

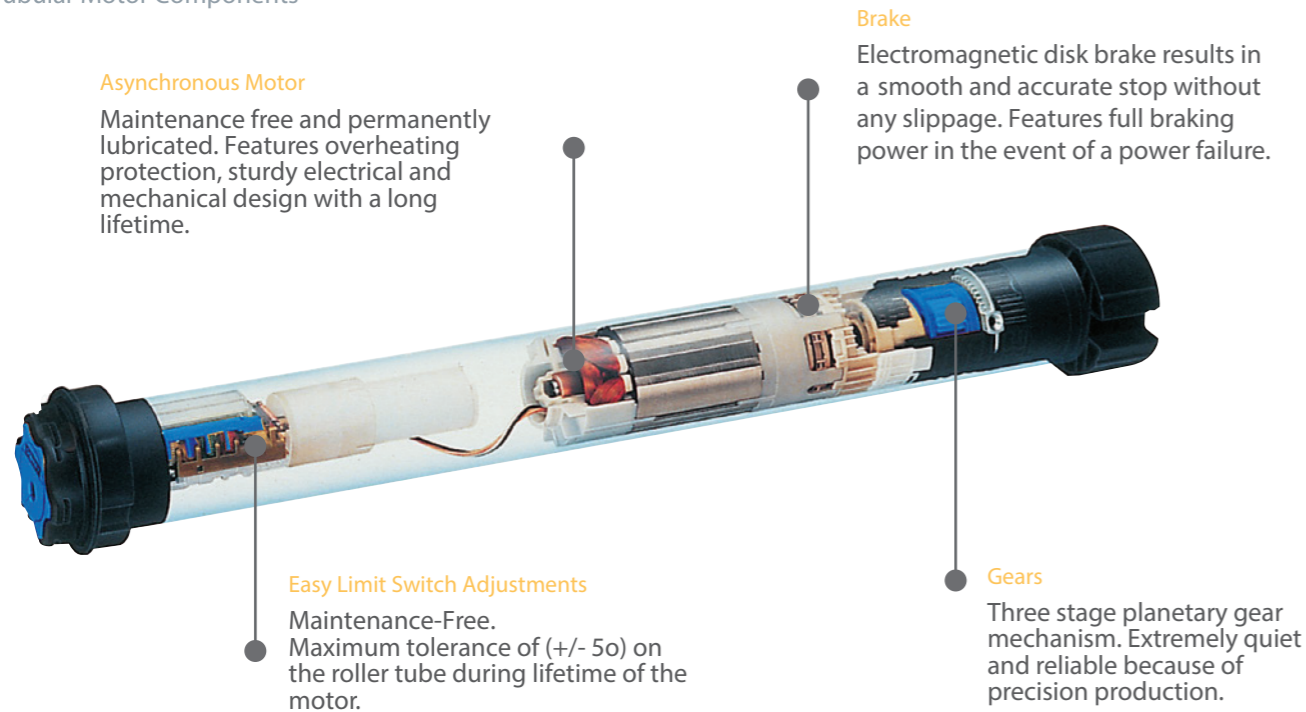

Dual Motor Operator

Dual operation shutters that combine motor with manual override function allows the versatility of operation even in absence of power.

Tubular Motor Characteristics (220V/60 Hz - 230V/50Hz)

Motor Type	Torque	Speed
Wireless Motor	6 NM - 38 NM	14 rpm - 20 rpm
Wired Motor	8 NM - 120 NM	14 rpm
Motor + Manual	8 NM - 120 NM	14 rpm - 20 rpm
Heavy Motor	250 NM	8 rpm

Remote Control Options



Our automation solutions give you control to operate your motorized rolling shutters and other devices with wireless and customizable remote controls as well as from your favorite smart device from any location.

حلول الأتمتة تعطي إمكانية التحكم بالمشتر وغيره من الأجهزة عن طريق أنظمة التحكم اللاسلكية أو الأجهزة الذكية المحمولة من أي مكان.



The “MONOBLOC”

SOLEX presents its aluminum aesthetic system that combines high performance windows with rolling shutters and mosquito nets to provide complete protection for your family and furniture.

The MONOBLOC has two profiles SL 18 & SL 24. It gives clients the ability to choose the right profile that fits their needs and budget.

SL 18 :

Thickness : 2 mm
Frame width : 210 mm
Glass Size : Up to 18 mm
Configuration : 2,3 or 4 panels
Maximum W x H : 4000 x 2600 mm
Minimum W x H : 1000 x 1000 mm

SL 24 :

Profile thickness : 1.8 mm
Frame width : 209 mm
Glass size : Up to 24 mm glass
Configuration : 2,3 or 4 panels
Maximum W x H : 4000 x 2600 mm
Minimum W x H : 1000 x 1000 mm



Automation Systems

أنظمة الأتمتة

Our automation solutions give you control to operate your motorized rolling shutters, blinds, awnings, lighting and other devices with wireless and customizable remote controls as well as from your favorite smart device from any location.

حلول الأتمتة تعطي إمكانية التحكم بالشتر والسنانر الداخلية و المظلات و الإضاءة وغيرها من الأجهزة عن طريق أنظمة التحكم اللاسلكية أو الأجهزة الذكية المحمولة من أي مكان.

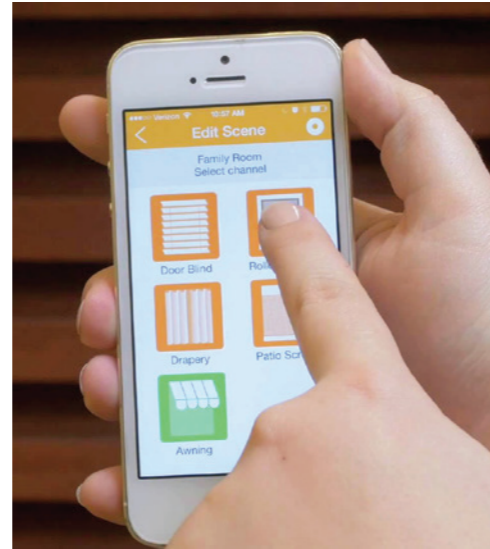

Automation Systems

TaHoma®

Remote control and management of the home

A fully connected house

Opening

- Multi equipment: over 100 devices by Somfy are compatible with TaHoma.
- Multi-brand: connected home devices and appliances from the major brands are compatible with TaHoma

Intuitivite

- Customised interface
- 3 intuitive menus:
 - Scenario, to create connected life moments...
 - Agenda, to live in line with your desires
 - Smart, to define advanced programming (sensors, detectors, clock, etc.)

Simplicity

- Simple to install: each device added without reconfiguring the system
- Easy-to-use



Activation mode – Sensitive button on the box



Technical characteristics

Protocols / Frequency	io feedback signal (868 Mhz) / RTS (433 Mhz)	Colour	White
Dimensions (lxPxh)	110 x 71,25 x 28,13 mm	Other	LED (red/white) / "Reset" button
Weight	≈ 235 gr	In the box	1x USB cable/ 1x RJ 1 45m cable 2x Installation Guide / 1x Disclaimer
Power	5Vdc/ 2A		
Consumption	0,1 A (nominal)		
Connectors	1x Ethernet RJ 1 / 45x Micro-USB / 1x USB port		
Operating temperature	°0+C to °50+C / IP 20		

TaHoma partners



Compatible protocols



Functional Specifications

MAX. EQUIPMENT (ALL THE PROTOCOLS): 200*			
Equipment	Max	Equipment	Max
io equipment	200	OVP equipment	200
RTS equipment	50	Caméras equipment	5
RTD equipment	50	Zwave equipment	232
RTDS equipment	50	Activation mode equipment	20
Ramses equipment	3 Evotouch	HUE Bridge	50) 1 lamps)
EnOcean equipment	128		

Functions	Max
Scenario	40
Day	40
SMART	20
Other	Max
Condition in a SMART	6**
E-mail alert	3**
SMS alert	3**
Push alert	unlimited

*More equipments it's possible but not guaranteed.
**Only for TaHoma Premium offer.

Connexoon Access

Remote control and management of equipment

Connected Access from the first device

Easy to install

No need for an Internet connection on site to install the box and pair the equipment. Connexoon Access installs simply in Plug & Play mode. Ideal for renovation projects.

Easy to Use

Intuitive, smart, fun... in short on trend! Connexoon Access was designed to make life easier and more pleasant in 1 click, from a smartphone.



Plug & play installation

Brand-new scenarios

Welcome

Open the gate and garage door, and turn on the lights just before arriving.

Everything closes automatically when the car is parked...thanks to GPS. Welcome home.

Check access

Check the status of entries and alarms with 1 click...reassure yourself the house is secure, even when you're away from home



Technical characteristics

Mains power supply	230-220 V - 60-50 Hz	Working stroke	480 mm
Minimum room needed behind the leaf*	160 mm	Opening time to °90	15 to 30 s depending on the installation
Maximum hinge pins offset**	183 mm	RTS radio frequency	433.42 MHz
Motor voltage	230 V	Number of remote controls	128 channels maximum
Maximum power consumption	210 W	Index of protection	IP 44
Lighting output	230 V - 60 W	Operating temperature	*20-C to °60+C
Accessories power supply	24 Vac / 360 mA		
Thrust force	2,000 N		

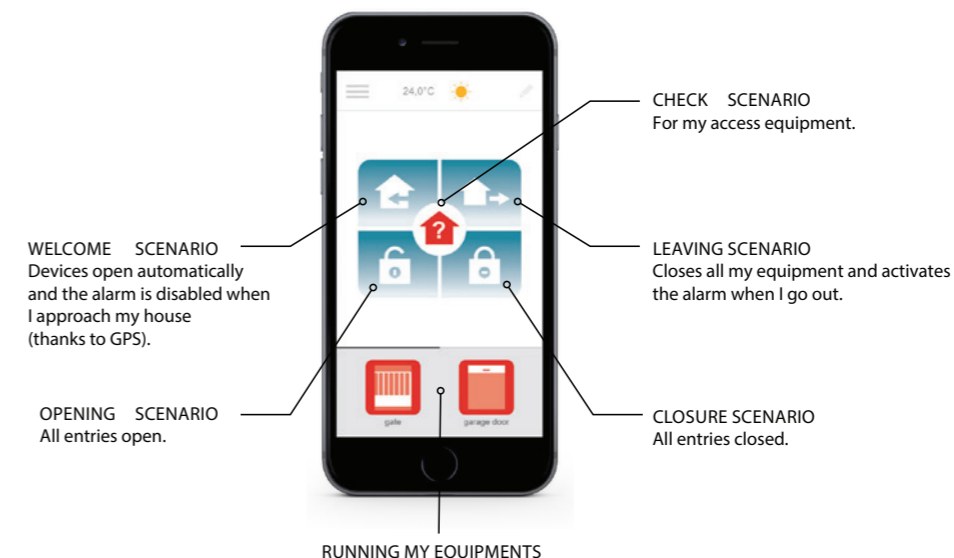

Compatible protocol

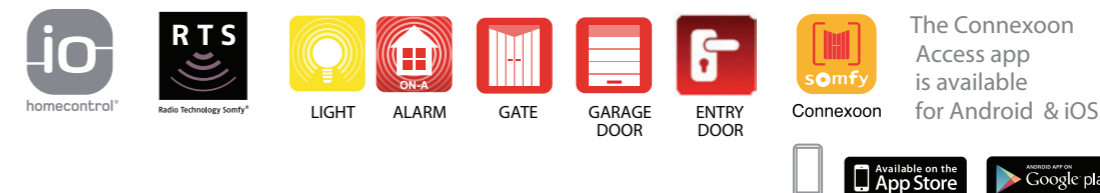

The Connexoon Access app is available for Android & iOS.



Packs

Connexoon io	Connexoon RTS	Elixo 3 500S Connexoon io	Axovia Multi Pro 3S Connexoon io
Ref. 1811429	Plug Type C: Ref. 1811589 Plug Type G (UK, UAE): Ref. 1811592	Ref. 1216480	Ref. 1216481

Strategic Partners

somfy®



V/ VENUS

ALURAY
Premium Aluminium Slats

